

A CENTURY IN WING, BUCKINGHAMSHIRE

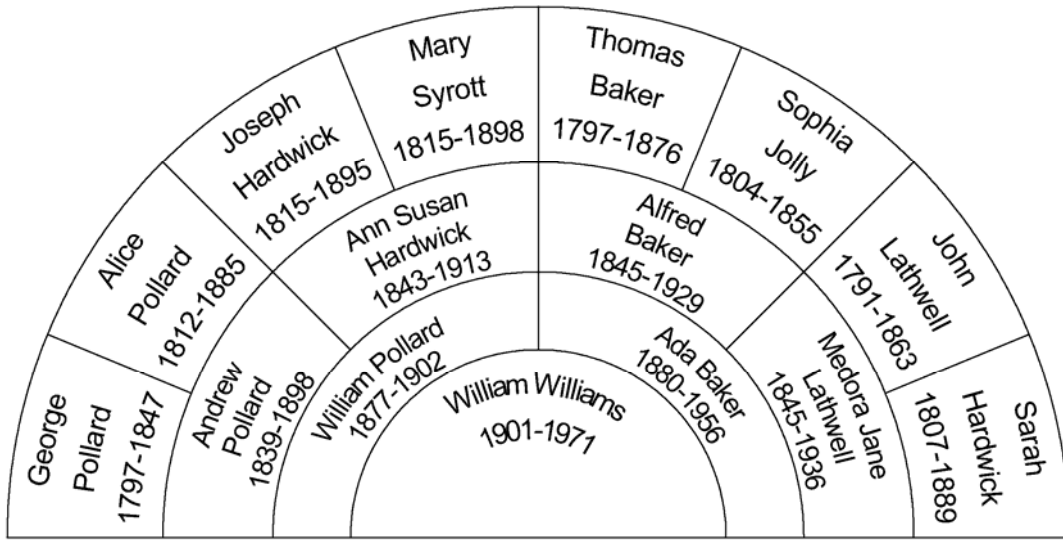

Wing, circa 1883

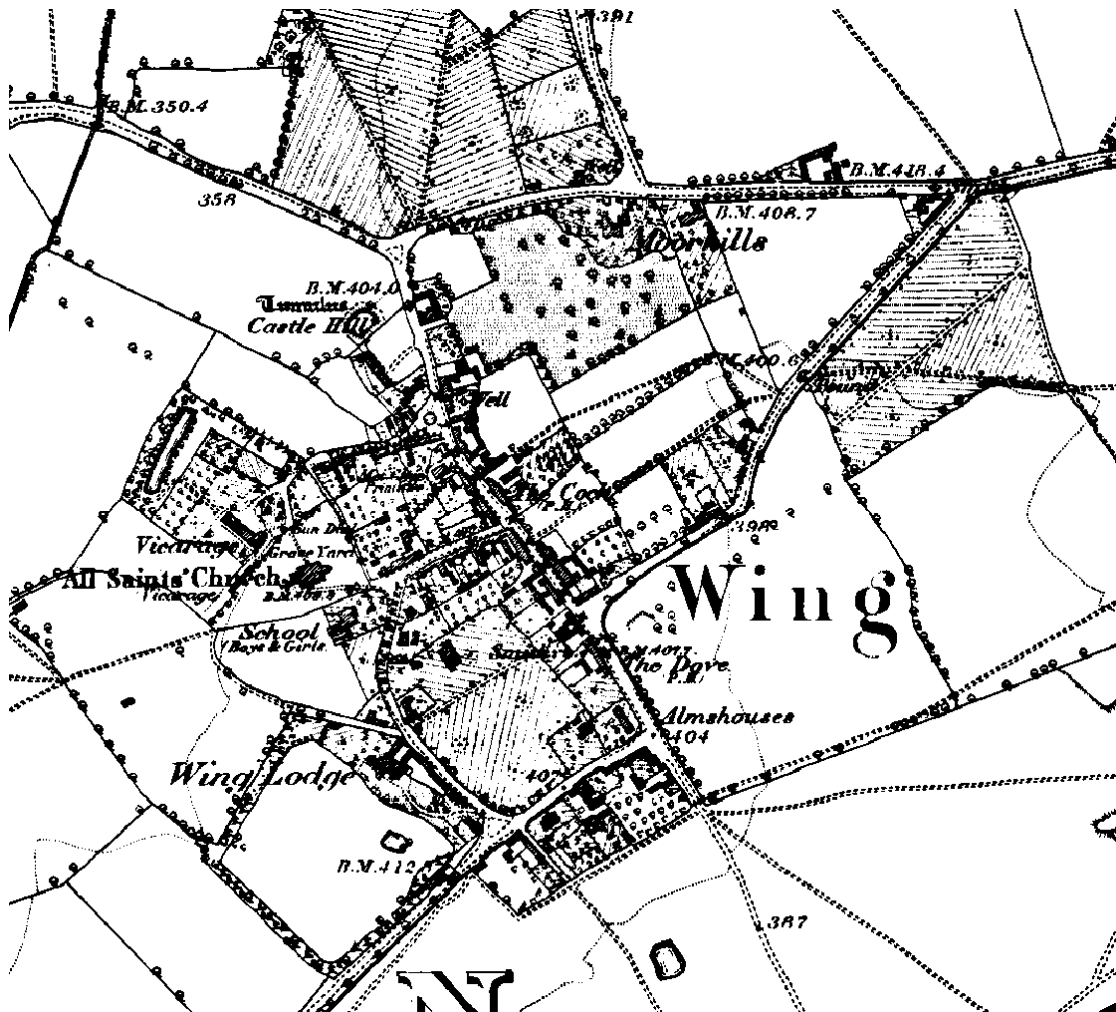

GEORGE & ALICE POLLARD

The first of Bill's great-grandfathers, George Pollard, was born in Wing on 30 January 1797ⁱ. He was the fifth child of Joram and Sarah Pollard, and his birth came two weeks after the family would have celebrated eldest child John's 8th birthday¹.

Joram and Sarah had six children in allⁱ but, as was common, they had lost one of George's older brothers, Joseph, at only nine months old. Still, George had two remaining brothers, John and Andrew, to keep an eye on him, as well as sister Elizabeth. The family was joined by another girl, Sarah, in 1799, rounding out the family.

The village of Wing is three miles south-west of Leighton Buzzard, near the road from that town to Aylesbury. At the time of George's birth the population numbered around 1,000 and this was to grow steadily over the coming century.

Unless a young lad had the good fortune to be born into a family plying a trade (or better yet into a family of fortune), he was most likely destined to become yet another of the ubiquitous agricultural labourers. In an economy still dependent on agriculture, the ag labs played a vital role in keeping things ticking over but offered only a subsistence lifestyle to the labourer and his family. This seemed likely to be the fate of our George, but he had another option open to him – the army.

Twelve days after his sixteenth birthday, George joined the 14th Regiment of Foot at Hertfordⁱⁱ. This Buckinghamshire Regiment was at that time comprised of two battalions, and a third specially formed one which was to find glory at the Battle of Waterloo in 1815. But that is not George's story. Instead, he served with one of the other Battalions in the Mediterranean until 1818.

It would appear that the army was confused or misled as to George's actual date of birth. His discharge documents indicate that his date of birth was originally given as 10 February 1798, a full year after his actual birth. This actually worked against George, as credit was not given for underage service – accordingly the three years George served from 1813 to 1816 is recorded for posterity but was not counted as part of his length of service.

In October 1818 Private George Pollard was off to see even more foreign parts when the 1st Battalion was shipped out to India. The British Empire was expanding into India, and naturally this process did not run smoothly. The presence of English forces was required to resolve any differences of opinion.

Thirteen years of service in India followed – it appears George performed his role adequately, never rising above the rank of Private, but his general conduct was that of a "good and efficient soldier... trustworthy" in the opinion of the Regimental Board responsible for processing his discharge at the end of his army career. Certainly India must have been a glamorous destination in the eyes of the other lads back home in Wing, at a time when very few people had the good fortune to be able to travel abroad.

The most dramatic incident of his army career would likely have been the 14th Foot's participation in the siege storming of the fortified town of Bhurtpore in December 1825

¹ Joram married Sarah Gibbard three months before the impending birth of John – an occurrence which seems to be the norm. The average man, overworked and underpaid, was reluctant to take on the cost of a wife and family until events deemed it absolutely necessary.

and January 1826. This was considered a vital victory, for the effect on moral of both sides, and for restricting the military power of the Bhurtpore stateⁱⁱⁱ. George's army recordsⁱⁱ confirm he was present at the campaign – twelve of his fellow privates were not lucky enough to survive the storming^{iv}.

While George was seldom in the care of the army hospital, he did have some health problems. Around 1828 it would seem his eyes began to trouble him – as an experienced soldier barely 30 years old this must have caused some difficulties. On 13 May 1831 the battalion was sent home to England, having been granted the badge of the Royal Tiger for their efforts. George was sent to Fort Pitt in Chatham, Kent, for evaluation at the army hospital there². After five months of treatment and observation, the Principal Medical Officer declared that George was officially unfit for service, with his vision nearly gone in both eyes from an unknown cause. He was accordingly discharged on 4 February 1832.

Thus it was that George returned home to Wing in 1832, age 35. Were the young women of Wing excited by the return of a prospective husband? George was 5' 5" tall (not tall by today's standards, but presumably respectable for the times), had grey eyes, light hair, was well travelled, and independently wealthy after a fashion - after factoring in the time-and-a-half credit for East Indies service, he had officially completed the minimum 20 years service to be eligible for an army pension, in his case the princely sum of 1'0½^v. There was however the small matter of his blindness, meaning any prospective bride might effectively be taking on an invalid.

We know at least one prospective bride was interested – Alice Pollard. She was actually a cousin of George, although she was born around the same time as George joined the army so it is likely they hadn't met until George's return. Alice was baptised on 28 March 1813ⁱ, and was the illegitimate daughter of Mary Pollard (Joram's younger sister).

Back in the days when women didn't work, any illegitimate child was a financial problem for the parish as they had to support both mother and child. It was therefore common for the parish to "make enquiries" as to whom the father of the child might be, and pursue him vigorously to meet his responsibilities. Depending on the views of the local clergyman or parish clerk, a baptism might be recorded as illegitimate, base-born, ill-gotten or any of a series of increasingly harsh phrases, and the father (if known) might be named and shamed in the baptism records. For genealogical purposes we are delighted when the father is recorded, as in this case – the wonderfully monikered Brightwell Holyman, labourer.

Brightwell Holyman, or to give the phonetic spelling, Britell Oliman^{vi}, was aged around 53 and Mary ten years younger when daughter Alice was born (if we assume his age at burial is roughly correctⁱ – he allegedly made it to 86). The couple did eventually marry three years after Alice was born, but there is no record of any brothers and sisters for Alice, who was 19 when George came home to Wing.

George Pollard and Alice Pollard married in Wing on 14 October 1832ⁱ. There are two items of note in the record of their marriage in the parish register. The first is that, while Alice Pollard was able to sign her name, George Pollard marked with an X. This may reflect the improved standards of schooling and literacy in the village – a school for both boys and girls opened in Wing in 1815, so while it would seem likely that George missed out altogether on schooling, it is possible that Alice attended. However it is highly probable that the only thing Alice could write was her name (in later documents

² Later the site of the first Army Medical School, established by Florence Nightingale in 1860.

she only marked with an X so literacy was clearly not a skill that she retained and used!) The second interesting item on the marriage certificate is that George is recorded as a widower.

<i>George Pollard</i>	of <i>this</i> Parish
<i>Widower</i>	
and <i>Alice Pollard</i>	of <i>this</i> Parish
<i>Spinster</i>	
were married in this <i>Church</i>	by <i>Banns</i> with Consent of
	this <i>fourteenth</i> Day of
<i>October</i>	in the Year One thousand eight hundred and <i>thirty two</i>
By me <i>John Felix Curate</i>	
This Marriage was solemnized between us	<i>George Pollard's Mark</i>
	<i>Alice Pollard</i>
In the Presence of	<i>John Felix</i>
	<i>Isaac Newman</i>
No. 173.	

Figure 1: Pollard marriage entry in the Wing parish registers¹

Where and when did George come by a first wife? This marriage presumably took place while he was in the army, and could have occurred anywhere. We also don't know whether there were any children of that union. Army chaplains did record marriages and children's births of the men in overseas service during this timeframe, but there is no marriage record for George amongst these Army Returns.

George and Alice had two children together: Mary Ann baptised 17 Aug 1835ⁱ and Andrew born 12 Mar 1839^{vii}. I'm not sure exactly what became of Mary Ann – she was with the family up until the 1851 census, after which she presumably married (although not in Wing) and moved away. You may read more about Andrew in a subsequent chapter.

There was a bit of excitement in the village around the time the Pollard children were born. Wealthy farmer Thomas Adams was found shot to death a few days after Christmas in 1837, and one of his sons was charged with the murder. He was eventually found not guilty (despite what appears to be a significant amount of evidence to the contrary), although he was found guilty of stealing from his father the day of the murder and was sentenced to transportation. Like today, this tragic event would have caused quite a stir – indeed there was apparently quite an influx of visitors from throughout Buckinghamshire who came to see the shed in which Thomas met his end^{viii}.

As a blind pensioner, George would not have worked, and perhaps was more of a burden for Alice in their home in Chapel Lane^{vi} in Burcot (a hamlet of Wing) – in fact for much of the 1840s Alice took care of her two small children, her invalid husband and her elderly father who also lived with the family. Brightwell died in 1846ⁱ, and George on the 23rd December of the following year^{ix}.

George's death certificate reveals another fact about his health – the cause of death is listed as Epilepsy 10 years. With the benefit of modern medical knowledge, it seems curious that this ailment was relatively newly acquired, rather than being present from

birth. Perhaps this was connected to a wider health problem, along with his blindness? We hope George didn't suffer too much.

As was common then, Alice did remarry after George's death – but not till her children were old enough to have their own families. She made a living as a charwoman in the interim^x, then on 11 November 1860 she married Richard Leeⁱ, also a native of Wing and also widowed. Richard was an agricultural labourer^{xi}.

In the 1861 census, we find Alice caring for others again. This time she has been included in the household of a neighbour who had a new baby, and Alice is listed as Nurse^{xii}.

The couple subsequently moved to nearby Cheddington^{xi}, where Alice died aged 72. She was buried at Wing on 4 May 1885^{xiii}, as was Richard after his death the following year.

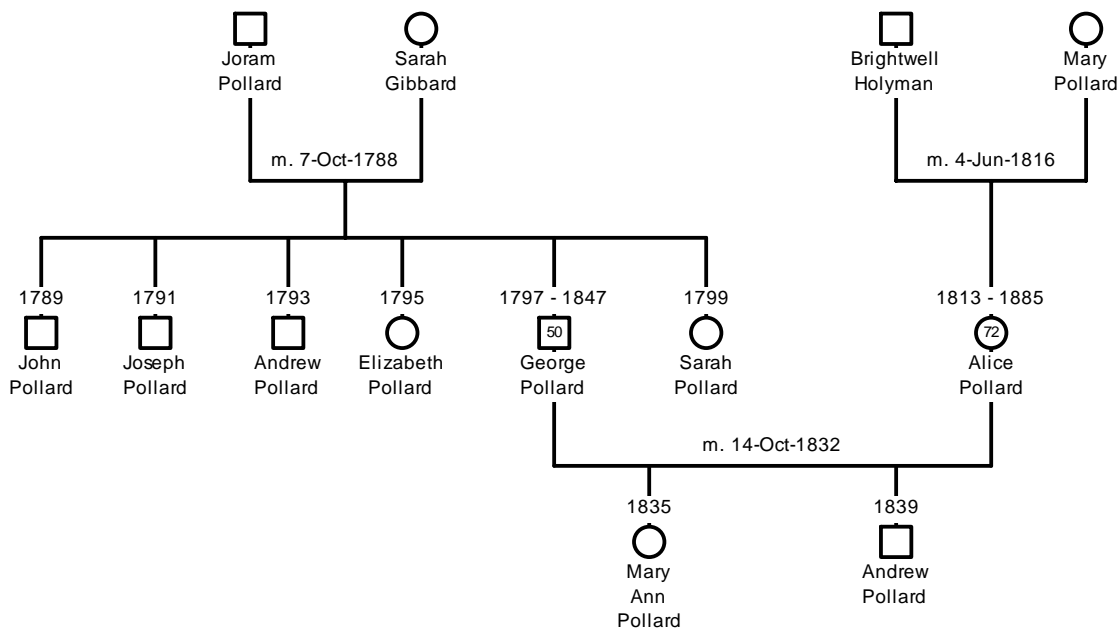

ⁱ Parish registers of All Saints Church of Wing, Buckinghamshire, Church of Jesus Christ of Latter-day Saints 1042446 [Microfilm of original records held at Buckinghamshire Record Office]

ⁱⁱ Discharge Documents of Private George Pollard 14th Regiment of Foot, 7 February 1832, Church of Jesus Christ of Latter-day Saints 876905 [Microfilm of original record in the WO97 series held at the National Archives, London]

ⁱⁱⁱ Report on the capture of Bhurtpore, The Times London, 30 May 1826

^{iv} Memorial at Meerut as transcribed <www.angelfire.com/mp/memorials/14bhurt.htm>

^v Regimental Registers of Pensioners, Church of Jesus Christ of Latter-day Saints 854656 [Microfilm of original record in the WO120 series held at The National Archives, Kew, London]

^{vi} 1841 Census of Buckinghamshire, piece 51 folio 6 pg 18, S&N Genealogy Supplies CD [scans of original enumerators books held at The National Archives, Kew, London]

^{vii} Birth certificate of Andrew Pollard, Leighton Buzzard vol 6 pg 86 Mar 1839 quarter

^{viii} As reported in The Times, London, 1839

^{ix} Death certificate of George Pollard, Leighton Buzzard vol 6 pg 67 Dec 1847 quarter

^x 1851 Census of Buckinghamshire, piece 1756 folio 226, Buckinghamshire Family History Society CD [transcripts of original records held at The National Archives, Kew, London]

^{xi} 1881 Census, piece 1644 folio 48 pg 6, Ancestry Plus database made available through the Auckland City Library [transcripts and scans of original enumerators books held at The National Archives, Kew, London]

-
- ^{xii} 1861 Census of Buckinghamshire, piece1007 folio 26 pg3, Buckinghamshire Genealogical Society CD [transcripts of original records held at The National Archives, Kew, London]
- ^{xiii} Parish registers of All Saints Church of Wing, Buckinghamshire, Church of Jesus Christ of Latter-day Saints 1967010 [Microfilm of original records held at Buckinghamshire Record Office]

JOSEPH AND MARY HARDWICK

The second of Bill William's great-grandfathers was also a native of Wing. John and Susannah Hardwick's youngest child, Joseph, was born in 1815 and baptised at All Saints Church in Wing on 26 November of that yearⁱ. The Hardwick family was well-rounded and relatively hardy – three boys, two girls, no children lost to infant mortality, although Joseph's eldest brother Abel did die at age 23 when Joseph was 13.

At age 18, Joseph married Mary Syrott. Mary was the daughter of John and Ann Syrott and was born in the neighbouring hamlet of Burcot. She was baptised at Wing on 15 Feb 1817ⁱ, but if we can believe the age she gives on census records she must have been born a couple of years earlier³ – so perhaps John and Ann were only infrequent visitors to the Wing church (around a mile's walk south of Burcot) and in no particular hurry to baptise their daughter. Mary had an older sister, Sarah, but they are the only children of John and Ann Syrott baptised in Wing. However there are a couple of male Syrotts resident in Burcot and Wing in the 1841 censusⁱⁱ of the right age to be brothers to Mary and Sarah, and "our" Syrott parents are the only ones appearing in the parish registers at the beginning of the 1800s, so it is quite possible that Mary had both an older and a younger brother.

Joseph and Mary married 20 June 1833ⁱ, three months after Joseph's father's death. As with the Pollard marriage, there are two interesting points to the marriage record. One of the witnesses was Joseph Bull – Joseph's not-quite-brother-in-law. Joseph Hardwick's elder sister Mary Ann and Joseph Bull were to baptise their first child Ann on Christmas day of 1833. However they did not marry until 1850 – it would appear that an estrangement occurred, Mary Ann married another local lad Baldwin Thorn in 1835 but after his death she returned to the still-unmarried Joseph!

And, as with Alice Pollard, Mary was able to sign her name. We see here some of the variations in the Syrott name – it has been recorded in the parish register as Syrott, but Mary has signed Sirriet. There are numerous variations on the spelling of the surname in a time when the general population was only just starting to become literate – the only constants in this case are an "s" at the beginning³, at least one "r" in the middle and at least one "t" at the end – any vowel combinations in between accepted!

Like his father John before him, Joseph made a living as a carpenter. County directories of the 1800s record the prominent citizens of each village, together with tradesmen (and sometimes tradeswomen). The directories were produced at increasingly regular intervals by a number of parties, including the Post Office, but many have not survived. Joseph Hardwick appears in a number of these, dated from 1839 to 1883. He presumably learned his trade from his father, and you can imagine they most likely worked together until John's death in 1833. Neither father nor son appears in the 1830 directory from Pigotsⁱⁱⁱ which has relatively few listings of Wing tradesmen, but in the 1839 directory from Robsons^{iv} we find Joseph listed. That year there were another four carpenters in Wing (population 1152), along with two bricklayers. Interestingly the competition seemed to dwindle over time – however it does appear to be a family trade, so perhaps assorted sons of the Bolton, Denchfield, Dimmock and Hardwick families were on hand to assist with the carpentry needs of a growing population.

³ Civil registration of births, deaths and marriages began 1 July 1837 – before this date the only record of a birth would be the child's baptism (if they were baptised), and most parish church registers only record the date of baptism, not the date of birth.

Wing.		Burcot.
Massey Oliver, esq. Wing cottage	Hounslow Henry, fruiterer, & skin & fur dealer	Adams Henry Charles, farmer
Ouvry Rev. Peter Thos. M.A., J.P. [vicar]	Mortimer William, registrar of births & deaths for Wing district	Biggs Edward, farmer
Welburn Rev. Dale John [curate]	Munday William, shopkeeper	Bone Joseph, sheep dealer
Attenborough Edwin, farmer	Newett John, farm bailiff to Mrs. Jane Woodman, Church farm	Denchfield Hannah (Mrs.), <i>Star Belle</i> , & shopkeeper
Attwood Richard, <i>Cock</i> , & post office	Paine James, farmer	Faulkner Joseph, baker
Bandy William, shopkeeper	Rickard Bernard, bricklayer	Hart Philip, farmer & auctioneer
Bedford Joseph, boot & shoe maker	Rogers Henry, baker	Heley James & Thomas, farmers, corn & oil cake dealers
Biggs James, farmer	Rogers Joseph, <i>Dove</i>	Jennings John, shopkeeper
Bolton William, carpenter	Rose George, farmer	Smith Jane (Mrs.), farmer
Brown Thomas, farrier	Sale Thomas Ginger, butcher	Valentine Robert, farmer, Burcott ldg Letters through Leighton Buzzard, which is the nearest money order office
Capp Stephen, yeoman	Sear Joseph, bricklayer	
Capp Thomas, boot & shoe maker	Thorne Thomas, shopkeeper	
Cleaver George, shopkeeper	Webster Alexander, local agent for the Right Hon. Lord Overstone	Crafton.
Coles Henry, shopkeeper	Windmill Catherine (Miss) & Henry, <i>Queen's Head</i>	Collins Mary (Mrs.), farmer
Cook Charles, farm bailiff to Wm. Cox	Windmill John, shopkeeper	Markham Charles, master of Baron Rothschild's breeding stud estblshmnt
Denchfield George, carpenter	Worster Thomas, baker	Willison Robert, farmer
Denchfield Levi, machinist & ironfounder	Young John, tailor	Letters through Leighton Buzzard, which is the nearest money order office
Denchfield Seth, <i>Royal Oak</i>	Letters through Leighton Buzzard	
Dimmock Thomas, carrier & coal dealer	Ascot.	Littleworth.
Dolamore John, shopkeeper	Brandon Joseph, grazier & blacksmith	Dimmock William, carpenter & shopkpr
Foster Henry & Thomas, blacksmiths	Hamilton —, bricklayer	Page William, butcher
Fontaine Bernard, farmer	Hart Thomas, farmer	Rogers Edmund, beer retailer, butcher & shopkeeper
Gates John, farmer & cattle dealer, Wing park farm	Prentice Martha (Mrs.), farmer	Letters through Leighton Buzzard, which is the nearest money order office
Hardwick Joseph, carpenter	Stevens Alfred, grazier	
Harris Rd. miller & farmer, Wing mill	Letters through Leighton Buzzard, which is the nearest money order office	
Hedges Richard, farmer		
Heley William, maltster, corn dealer & grazier		
Mallett Thomas, baker		

Figure 2: 1864 Post Office directory^v

Joseph and Mary's first child Elizabethⁱ was baptised a year after their marriage, and was joined at regular intervals by siblings Abel, John, George, Ann Susan, Joseph, Mary Jane, and William. Curiously enough, while the eldest two were baptised at All Saints Church there are no baptism records for the remaining children in the parish registers. This generation of Hardwick children was also pretty healthy – little Joseph died at seven but the rest made it through to adulthood.

Joseph's four surviving sons all followed him into the carpentry trade, however once grown they scattered to various neighbouring villages and towns^{vi} where work was no doubt more plentiful. The girls married local boys practising a variety of different trades – Elizabeth married George Page, a hairdresser, Ann chose Andrew Pollard, a blacksmith, and Mary Jane married John Dimmock, a domestic groom, and all these families stayed in Wing. In fact, in the 1871 census we find Joseph and Mary Hardwick and their two youngest children living right next door to their daughter Ann and her family^{vii} in Vicarage Lane, Wing. You can read more about Ann and Andrew in a later chapter

Joseph and Mary declared themselves to be the same age as each other on each census night – this extends right down to each becoming a year younger by 1881! In the 1891 census we find the couple officially lodging with Joseph's widowed sister Mary Bull, in Almshouse Number 1. Wing had eight almshouses – a block of eight residences in one stone building, founded in the 1500s to house the elderly poor, and Mary had evidently been chosen to receive this form of parish relief. Most of the almshouses contained several elderly residents.



Figure 3: Almshouses, Aylesbury Rd, Wing^{viii}

Joseph died in February 1895 and was buried in the Wing churchyard^{ix}, followed by Mary in August 1898 – both made it to their eighties.

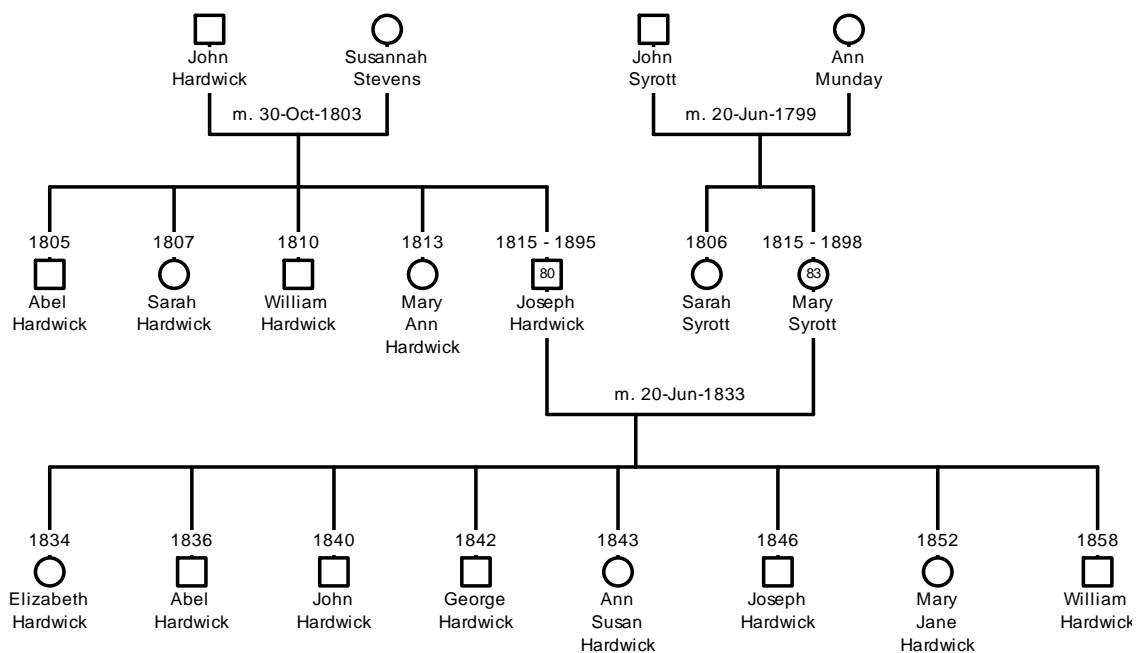

ⁱ Parish registers of All Saints Church of Wing, Buckinghamshire, Church of Jesus Christ of Latter-day Saints 1042446 [Microfilm of original records held at Buckinghamshire Record Office]

ⁱⁱ 1841 Census of Buckinghamshire, piece 51, S&N Genealogy Supplies CD [scans of original enumerators books held at The National Archives, Kew, London]

ⁱⁱⁱ 1830 Pigots Directory of Buckinghamshire, Historical Directories <www.historicaldirectories.org>

^{iv} 1839 Robsons Commercial Directory of the Six Counties forming the Norfolk Circuit, Historical Directories <www.historicaldirectories.org>

^v 1864 Post Office Directory of Buckinghamshire, Historical Directories, <www.historicaldirectories.org>

^{vi} 1871 Census, Ancestry Plus database made available through the Auckland City Library [transcripts and scans of original enumerators books held at The National Archives, Kew, London]

^{vii} 1871 Census, piece 1563 folio 10 page 12, Ancestry Plus database made available through the Auckland City Library [transcripts and scans of original enumerators books held at The National Archives, Kew, London]

^{viii} Photo by Kevin Quick and used with permission, <www.countryviews.com>

^{ix} Parish registers of All Saints Church of Wing, Buckinghamshire, Church of Jesus Christ of Latter-day Saints 1967010 [Microfilm of original records held at Buckinghamshire Record Office]

THOMAS AND SOPHIA BAKER

We come now to our first humble agricultural labourer – no family is complete without a generous handful of these! Our families in Wing so far have been relatively small – not so the Bakers, who baptised their ninth and youngest child Thomas on 19 Feb 1797ⁱ. Thomas' father John was a labourerⁱⁱ – raising nine children on a labourer's wage must have been extremely challenging. At the time of the baptism of Thomas' brother Richard in 1789, the parish clerk has noted a "P" next to the entry – this generally denotes either pauper or that the family was receiving parish relief.

Our Thomas would have likely had a very austere childhood – even today it is likely a younger child will have hand-me-downs, and it is hard to imagine Thomas had any luxuries or special treats at all. Mother Maria (maiden name Williams!) must have needed all her household management skills to keep the family fed and clothed.

In 1821 Thomas married Sophia Jolly. Sophia was the daughter of John Jolly (yes, Wing-born) and Ann Stopps Parson from Ivinghoe, a neighbouring town. Like many other couples of the time, they married in the bride's home parishⁱⁱⁱ, but settled in the groom's parish to raise their family. The Wing parish records show six children baptised to John and Ann Jolly, however there is evidence that there were perhaps more siblings for Sophia.

One of the witnesses to the marriage of Thomas and Sophia was C Smith. This is believed to be Cornelius Smith, the local schoolmaster^{iv} who had come to Wing from London. In 1819 Cornelius had married one Susannah Jolly, whose baptism does not appear in the Wing parish records. Was his appearance as witness to Thomas and Sophia's marriage one as brother-in-law to Sophia? There are further snippets of evidence possibly linking Susannah (born around 1800) and Sophia as sisters – a Joseph Jolly (Sophia did have a brother of that name) was the witness at Susannah's wedding. However the most intriguing piece of evidence comes in the naming of Thomas and Sophia's eldest daughter, Eliza Smith Baker.

Surnames were occasionally used as middle names, even when middle names themselves were less common. Often such a name would be the maiden name of the mother, or in the case of an illegitimate child, the surname of the father! Children could also be named after local "people of importance" or elderly relatives with no apparent heir.....In this case, Cornelius and Susannah Smith had a daughter Eliza in 1820. It is not known what happened to her as the Smiths moved to Durham in the 1820s^v – quite a distance in those days! However it is possible that Eliza died, and Sophia, feeling the loss of both her sister and her niece, named her own eldest daughter after her – Eliza Smith Baker in 1825.

Thomas and Sophia had numerous children and, possibly like the Jollys before them, did not appear to baptise all their children. Stephen, Mercy and Joseph are the three children at home with their parents in the 1841 census^{vi}. This census, the earliest one to record details of individuals rather than just a head count, lists the members of each household, but not their relationship to each other – so can we be certain these three Baker children were really theirs and not part of the extended Baker family? It was not uncommon for people to be staying with relatives (either on a just-visiting or long-term basis) on census night – for example that year daughter Ruth is listed together with her grandmother Ann Joley [sic] in the household of Ann's youngest daughter Mariane – now married and known as Mary Capp – and her family. And coincidentally it is these three children for whom there is no baptism in the Wing parish records. Luckily we can confirm that Thomas was Stephen and Joseph's father from the two son's marriage

records – in the case of Mercy we can only assume she was a daughter rather than a more distant relative as she died age 11.

Mary Gaffer	90		
Thomas Baker	54		
Sophia do	38		
Stephen do	18		
Mercy Baker	3		
Joseph do	1		

Figure 4: 1841 census record for the Bakers^{vi}

Mercy was not the only child of the family to die young. You will note from the tree below that there were two sons named Alfred – the first died in 1840 age 10ⁱ and it was not uncommon back then to “reuse” names for later children. The younger Alfred Baker you will read more about in a later chapter.

Sophia gave birth to eight children over a period of twenty five years. When she died age 51 in 1855ⁱ, it is likely only the youngest two were still at home for father Thomas to continue raising on his own (although Alfred at almost 10 could well have been working by then) – perhaps Thomas was able to call on his married daughters for assistance.

Widowed Thomas, like his father before him, was a labourer all his life, and therefore not a wealthy man. In 1871 he was listed as a pauper (as any average retired person was likely to be in those days) and living with son Joseph and his family^{vii}. He lived on for another five years, making it to 79, and was buried in Wing on 2 July 1876ⁱ.

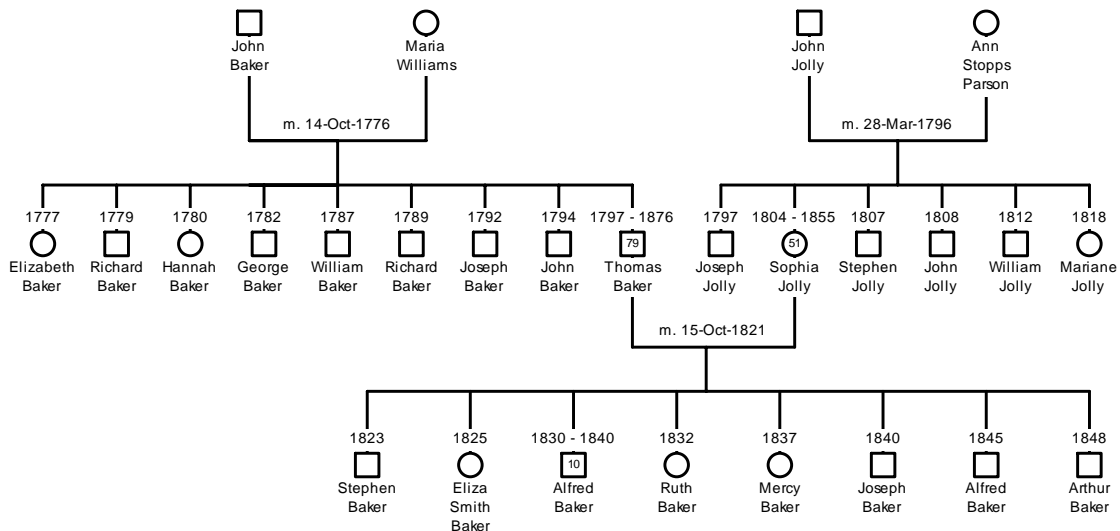

ⁱ Parish registers of All Saints Church of Wing, Buckinghamshire, Church of Jesus Christ of Latter-day Saints 1042446 [Microfilm of original records held at Buckinghamshire Record Office]

ⁱⁱ Bucks Posse Comitatus 1798, Drake Software 2003 [database of transcript made by Ian Beckett for the Buckinghamshire Record Society]

ⁱⁱⁱ Buckinghamshire Parish Registers – Marriage Transcripts from Phillimore's, Archive CD Books [facsimile reproduction of the original books of transcripts]

^{iv} Cornelius Smith biographical information provided by private email from John Ward, 20 December 2004

^v John Ward's website, <www.wardjc.com>

^{vi} 1841 Census of Buckinghamshire, piece 51, S&N Genealogy Supplies CD [scans of original enumerators books held at The National Archives, Kew, London]

^{vii} 1871 Census, piece 1563 folio 32 pg 14, Ancestry Plus database made available through the Auckland City Library [transcripts and scans of original enumerators books held at The National Archives, Kew, London]

JOHN AND SARAH LATHWELL

Researching families is made more difficult by the relatively small pool of forenames in general usage, which becomes more apparent the further back in time you go. Confusion abounds as to exactly which John, William, Elizabeth or Mary is being referred to – throw multiple marriages into the mix and you have a recipe for a headache! This can be amply demonstrated by the Lathwells.

John Lathwell was born around 1791 in Wing. Although census records give his birthplace as Wingⁱ, there is no baptism record for him. We do know that his father was Henry Lathwellⁱⁱ. John first appears in the parish registers with his first wife, Elizabeth, at the baptisms of their seven children from 1814 to 1834ⁱⁱⁱ. Elizabeth died the following year, a few months after the death of her 9 month old daughter, leaving John with three surviving daughters to care for. As he didn't remarry for some time, we can imagine his eldest daughter Sarah, aged around 13 at the time her mother died, likely raised the two younger girls while John was working as a labourer.

In 1839 Sarah baptised a son, George Kent Lathwell, closely followed a few months later by marriage to her son's father, George Kent, and moved out, so on census night in 1841 we find John age 50 at home with Ruth and Eliza^{iv}. The next year Ruth also married and moved out.

Meanwhile, on the other side of town.....

Sarah Hardwick was baptised 1 February 1807 in Wingⁱⁱⁱ. She was the second child of John and Susannah Hardwick, whom we have already met – Sarah is the elder sister of Joseph Hardwick. Wing was a smallish village – in a population of just over a thousand you tend to encounter the same families over and over!

On 23 September 1829 Sarah married her first husband – William Lathwellⁱⁱⁱ (yes, that's William not John). Now William we have a baptism for – he was the son of Henry and Ann Lathwell and was born 1799, not to be confused with William son of William and Alice Lathwell born 1790 (or indeed, William Heley Lathwell the son of Ann Lathwell and Lock Heley, also born in 1790). From the parish registers it appears there is only one Henry Lathwell fathering children around this time – and therefore John Lathwell and William Lathwell were almost certainly brothers.

Sarah and William had no children together. However William had been married previously (his first wife had died five months before his marriage to Sarah), so Sarah found herself stepmother to four-year-old Henry^{iv}. William died in 1844 and was buried in Wing on 10 March.

If one found oneself widowed with children, it was understandable that you would remarry relatively quickly, whether to provide a stepmother to raise your children, or to provide a stepfather and associated income for a family who would likely otherwise find themselves requiring parish relief. As her stepson Henry was 18 when William died and working as an agricultural labourer, Sarah did not have a brood of children to provide for. Nonetheless, she did not waste any time in remarrying – she married John Lathwell in St Saviour, Southwark, London on 11 August 1844ⁱⁱ.

The fact that they didn't marry at home in Wing was curious. Based on the information we have, the most likely explanation is that it was indeed an elopement – the unfortunate reason behind this being that it was then forbidden to marry your brother's widow^v. While banns were read in St Saviour (John presumably didn't have enough

spare cash to pay for a marriage licence which would speed things up and make it less private – or perhaps one or other of the couple had qualms about swearing there was no impediment to the marriage), no busybodies in St Saviour would have been aware of the fact that Sarah and John were not technically allowed to marry, and so would not have objected. However their marriage was void – legally it did not exist, and any children of the union were therefore technically illegitimate.

While John and Sarah obviously decided that marrying in Wing was out of the question, a couple in their situation was presumably not run out of town if they returned to live as a married couple afterwards. Their first and only child, Medora(h) Jane (the h was recorded on her birth certificate but apart from that does not appear in any of her records), was born in Wing on Christmas Day 1845^{vi}. Sarah was then 38 and John 55. Medora was an uncommon but not unique name – there are other Medoras born in Buckinghamshire around this time, but our Medora is almost unique in Wing (she shares the name with Medora Denchfield born 9 years later).

Columns:-	1	2	3	4	5	6	7	8	9	10
No.	When and where born	Name, if any	Sex	Name and surname of father	Name, surname and maiden surname of mother	Occupation of father	Signature, description and residence of informant	When registered	Signature of registrar	Name entered after registration
181	Twenty-fifth of December 1845. at Wing.	Medora Jane.	girl	John Lathwell	Sarah Lathwell formerly Hardwick.	Tobacco	The Mark of Sarah Lathwell Mother. Wing.	Twenty-fifth of December 1845.	William Mariner Registrar	

Figure 5: Medora Jane Lathwell's birth certificate^{vi}

Although she didn't have any full siblings, she did have a number of much older half-sisters – all married by the time of her baptism in 1849 – and a nephew (should that be half-nephew?) six years older than herself! Interestingly, two of Medora's nieces, the children of her half-sister Ruth and her husband George Jennings, were baptised on the same day as herself – perhaps the Lathwell clan were somewhat reticent about attending church and the vicar took the opportunity to baptise any and all when they did make an appearance.

Happily, given John's comparatively advanced age at Medora's birth, he was made of sturdy stock and survived her childhood. Aged 75 when he died, he was buried 23 April 1863 at Wingⁱⁱⁱ. Sarah, younger than John by almost 20 years, lived another 25 years and was buried 13 November 1889 aged 82 (beating younger brother Joseph's total of 80 years – good sturdy genes in that family too!)

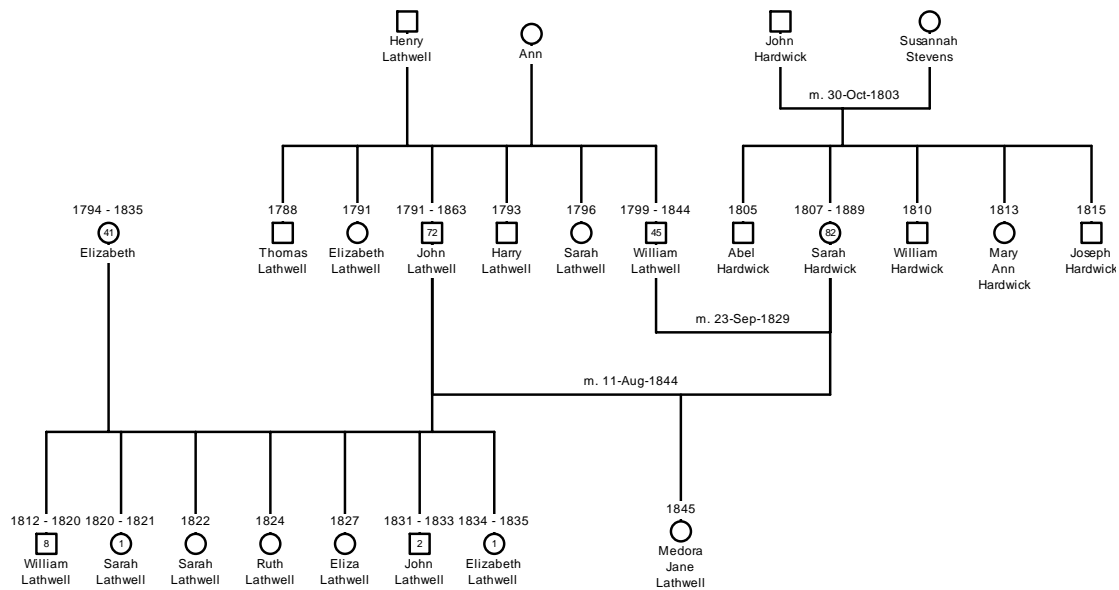

ⁱ 1851 Census of Buckinghamshire, piece 1756 folio 344, Buckinghamshire Family History Society CD [transcripts of original records held at The National Archives, Kew, London]

ⁱⁱ Marriage certificate, St Saviour vol 4 pg 507, September 1844 quarter.

ⁱⁱⁱ Parish registers of All Saints Church of Wing, Buckinghamshire, Church of Jesus Christ of Latter-day Saints 1042446 [Microfilm of original records held at Buckinghamshire Record Office]

^{iv} 1841 Census of Buckinghamshire, piece 51, S&N Genealogy Supplies CD [scans of original enumerators books held at The National Archives, Kew, London]

^v Colin R Chapman, Marriage Laws, Rites, Records & Customs, Lochin Publishing 1996

^{vi} Birth certificate of Medorah Jane Lathwell, Leighton Buzzard vol 6 page 88, Dec 1845 quarter

ALFRED BAKER AND MEDORA LATHWELL

Although Medora's father did live to a good age, he fell just short of seeing his youngest daughter marry. On 19 June 1864 Medora married Alfred Bakerⁱ, the son of Thomas and Sophia. Both were 18 years old.

The witnesses to the marriage were William and Eliza Bandy – Eliza being one of Medora's older half-sisters. It would seem that John Lathwell's children were close, despite the age gap (Eliza, the youngest surviving daughter of John's first marriage, was 16 years older than Medora).

Alfred and Medora's first child Ruth Jane was born six months after the weddingⁱⁱ. They didn't stop there, with Medora producing a baker's dozen of children, although one daughter, Ellen Jane, died at only four months old.

Throughout his working life, Alfred is recorded as either a thatcher or a general labourer – most likely he was a thatcher most of the time, but was lumped into the ag lab category when the census enumerator came calling! Thatched roofs, popular throughout the 18th and 19th century, began to decline in the late 19th century, primarily due to the railway networks that were now able to bring more exotic roofing materials like slate from Wales and Cornwall to those homes with a sturdy enough frame to support the weight.

Like Alfred, Medora also worked with straw. Many of the Wing women (and children) brought in a little extra money by straw plaiting, creating the long lengths of plaited straw that would later be made into hats. Straw hats were the most popular headgear of the century, having the benefit of being light and keeping out both sun and rain – very practical for outdoorsy folk. The straw plaiting and bonnet making industry was centred around Bedfordshire and Buckinghamshireⁱⁱⁱ, and Wing is a prime example of a village where the industry filled the days of many residents.

The straw plaiter's raw material was straw, often but not always locally grown, cut into 9 or 10 inch lengths, fumigated and bleached using sulphur fumes, and, particularly in the later 19th century, dyed. While the whole lengths could be plaited as they were, it was more common to split the straw lengthwise which provided thinner lengths that had both a shiny and dull side. This, combined with the increasing variety of patterns, enabled more exotic lengths of finished plait to be made.

While the women were free to work at plaiting in their own time, they were effectively at the mercy of the plait dealers. These local men (or sometimes women) would advise what patterns, colours and sizes of plait they were after, and purchase the finished hanks of plait from the plaiters – these would then go to the bonnet makers. Of course it was in a plaiter's best interests to be able to produce a variety of patterns to the required standard, or changing fashions could see them lose their source of income.

The work of a straw plaiter wasn't much fun. The work itself must have been very repetitive, numbing to both mind and fingers (occupational overuse syndrome, anyone?). The straw was brittle and needed to be moistened as it was worked – saliva was the best way to get this done but did lead to very chapped lips. A straw plaiter's fingers were inevitably roughened by the work, not to mention the carcinogenic effects on the body of the bleaching and dyeing methods used. However the work did have its benefits – women could work at home while keeping an eye on the children, or in groups of friends, and it was even possible to plait while wandering around the village

chatting to neighbours⁴. It was also a source of income in a time when these were few and far between for women (and children – in some villages “plait schools” operated where children of all ages would work a full day, and it was not uncommon for girls to work at home with their mother).



Figure 6: Straw plaiters^{iv}

Sometimes such “women’s work” is not recorded by census enumerators. However in the areas where straw plaiting was common, it was recorded and you can see that women of all ages undertook the work. In Medora’s case she is first recorded as a straw plaiter on the 1861 census at age 15^v - on the page on which she appears, there are other straw plaiters aged from 8 to 60. She was next recorded as a plaiter in the 1891 census when she was 45^{vi}. This was at a time of high demand – after child labour laws were introduced and enforced but before the full impact of cheaper imported plait was felt - so perhaps it became a full-time occupation again for Medora around this time (who still had a 3-year old underfoot, but the other children at home were old enough to take care of themselves).

In the 1881 census the family’s neighbour was Peter Thomas Ouvry, the vicar of Wing who baptised most of the family’s children^{vii}. By the 1891 census a new vicar, Francis Henry Tatham whose last post was in Hereford, was settled in at the Vicarage, and the Bakers still lived nearby, on the Cross^{vi} – the intersection of Vicarage Lane and High Street. This location was conveniently close to both the church and the school (which were next door to each other – very handy).

⁴ Including men friends – some young plaiters inevitably had a certain reputation which may or may not have been later borne out by the appearance of an illegitimate child or two!



Figure 7: Intersection of Vicarage Lane and High Street, Wing, late 1800s^{viii}

The paths of Alfred and Medora's children reflect the increasing mobility and opportunities by the end of the 1800s. Eldest daughter Ruth's job as a domestic servant took her to several different places, including Kent where she married an umbrella maker - they settled in Chesham, Buckinghamshire, and their third child was born just one day before the 1891 census. Another of the younger girls, Lily, also moved away from home as a domestic servant – in the 1901 census we find her in neighbouring Linslade working for a civil engineer and his family. William also moved away from Wing - in the 1901 census he is working as a gas stoker in Portland Prison, Dorset. Sarah was still unmarried (and not working) in 1901 – this gave her the flexibility to visit family members further afield, like helping sister Ruth with her brand new baby and two older children in 1891. Lizzie disappears from view after the 1881 census – she most likely married and moved away. Alfred and Medora's other children appear to have stayed in Wing. John is living with his Randall in-laws in 1901, while Amy Medora married local boy William Bandy in 1895. George Baker is a thatcher, living and presumably working with his father, however youngest son Harry tried a different trade – he is a bricklayers apprentice in the 1901 census. Ada you will learn more about later. The two youngest girls, Mary Jane (known as Jenny) and Hilda Florence, are both still at school by 1901.

Information on their lives after 1901 is harder to come by, as privacy laws generally block access to personal information within the last 100 years. However Alfred died in 1929 aged 83^{ix}, and Medora made it to 90^x, with the cause of death for both being simply old age.

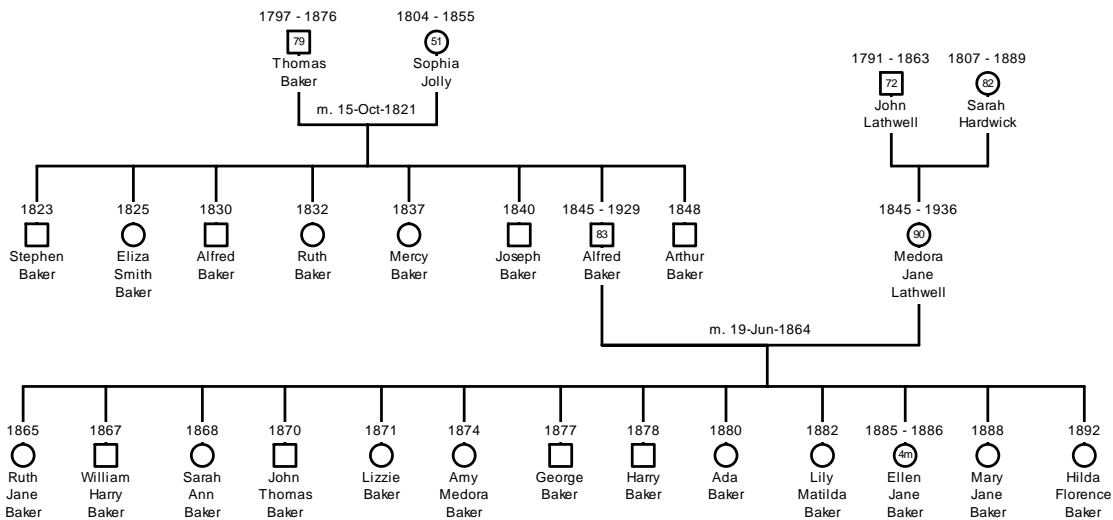

ⁱ Marriage certificate, parish records of All Saints Church of Wing, Buckinghamshire, Church of Jesus Christ of Latter-day Saints 1042446 [Microfilm of original records held at Buckinghamshire Record Office]; also Leighton Buzzard vol 3b pg 691, June 1864 quarter.

ⁱⁱ Parish records of All Saints Church of Wing, Buckinghamshire, Church of Jesus Christ of Latter-day Saints 1042446 [Microfilm of original records held at Buckinghamshire Record Office]

ⁱⁱⁱ Information on straw plaiting taken from a number of articles in Bucks Ancestor vol 13 no 1 March 2004, published by Buckinghamshire Genealogical Society

^{iv} Image from the Leighton Linslade Virtual Museum, <<http://www.leighton-museum.org.uk/>>

^v 1861 Census of Buckinghamshire, piece1007 folio 34 pg 20, Buckinghamshire Genealogical Society CD [transcripts of original records held at The National Archives, Kew, London]

^{vi} 1891 Census, piece 1266 folio 9 pg 11, Ancestry Plus database made available through the Auckland City Library [transcripts and scans of original enumerators books held at The National Archives, Kew, London]

^{vii} 1881 Census, piece 1643 folio 7 pg 8, Ancestry Plus database made available through the Auckland City Library [transcripts and scans of original enumerators books held at The National Archives, Kew, London]

^{viii} Wing Village website, <http://www.wingit.free-online.co.uk/village_photos.htm>

^{ix} Death certificate of Alfred Baker, Leighton Buzzard vol 3b pg 397, Mar 1929 quarter

^x Death certificate of Medora Baker, Aylesbury vol 3a pg 1683, Mar 1936 quarter

ANDREW POLLARD AND ANN SUSAN HARDWICK

Andrew Pollard was eight years old when his father George died in 1847. As the family did not have a great fortune, it is not surprising that mother Alice made do as a charwoman (although it is surprising that she did not remarry until after Andrew and his sister were grown) and eleven-year-old Andrew is out working as an ag lab in the 1851 censusⁱ.

On 30 December 1861 he married Ann Susan Hardwickⁱⁱ. Ann was the fifth child of Joseph and Mary Hardwick, and was born 14 December 1843ⁱⁱⁱ. This makes her just-turned 18 at the time of the marriage (although on the marriage certificate her age is given as 19), while Andrew was 22. The marriage was witnessed by one of Ann's older brothers, George, and Mary Ann Page – obviously sweethearts as they married a couple of years later^{iv}.

Ann and Andrew's first child, Joseph Andrew, was born less than six months after the wedding – a not uncommon occurrence in those days as we have already seen. Baby Joseph was a sturdy boy luckily – in March 1863 the village of Wing fell sick. The Medical Officer of Health determined this was due to “offensive house refuse” accumulating in the soil and contaminating the surface wells, and the generally unclean and overcrowded conditions that encouraged the spread of infectious disease^v. Indeed the situation was so bad that vicar Peter Ouvry decided to cancel the village's celebrations for the wedding of the Prince and Princess of Wales (an occasion of great excitement throughout the country, as each village and town collected subscriptions from the wealthy residents in order to put on a feast for the village along with other festivities). Instead it was decided that the money would be used to make a beneficial gift to the people of Wing – a good deep well with a pump.

The Pollards' second son, John Thomas, was born a couple of years later, but sadly died age two. While Ann was busy producing children, Andrew had the opportunity to complete a smithing apprenticeship, and by the 1871 census was working as a fully-fledged blacksmith in the village^{vi}. The four children at home didn't stop Ann working as well – she is listed as a dressmaker that year.

The village blacksmith likely had to utilise his skills for all manner of local needs – the description of one of the Pollard boys as “R.S.S. farrier, shoeing and general smith, agricultural implement repairer, fencing, ironwork, etc”^{vii} in an 1899 directory gives an idea of the jobs involved. On Andrew's death certificate he is listed as a master farrier^{viii} rather than a blacksmith, so we can deduce that this was the main focus of his business. From 1891 official qualifications were available in the skill of shoeing, and it is son Joseph's directory listing above that indicates that it was desirable to have such a qualification. Andrew and Ann had seven sons in total – little John Thomas died as an infant, but three of the surviving sons were blacksmiths, another two were grooms or stable boys and the last was a farmer, so all had a close connection with working horses.

The family lived for a long period on High Street^{ix}, a couple of doors along from the Dove Inn. On the other side of the Dove Inn were the almshouses where Ann's parents were living in 1891.

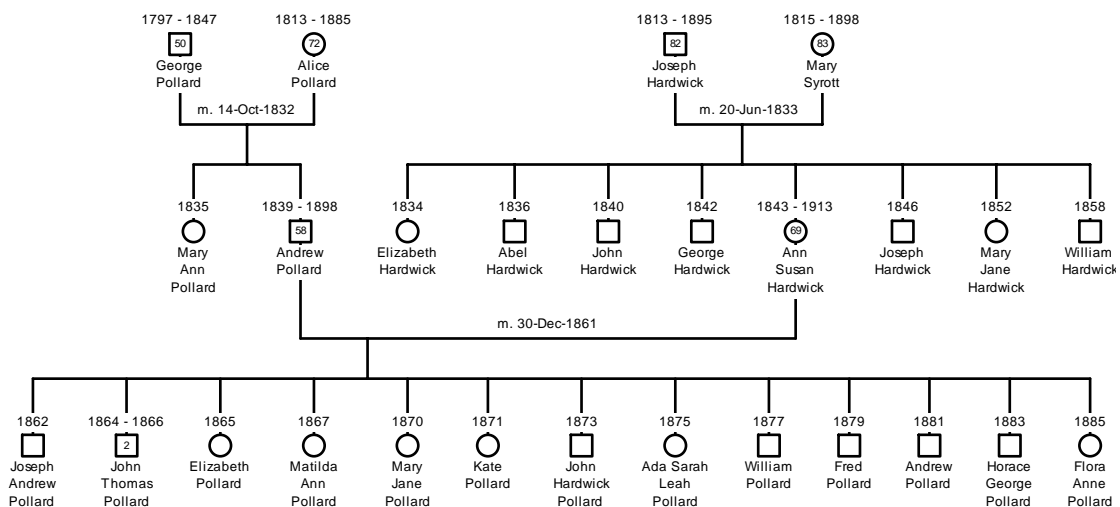

Figure 8: Dove Inn, Wing^x

Andrew died in 1898, just ten days short of his 59th birthday and was buried in Wing on 8 March^{xi}. His cause of death was recorded as cirrhosis of the liver, leading to heart failure^{viii}. After his death, wife Ann took over running the blacksmith's shop^{xii}. We can see from local directories that she was not the only widow running a business, but it is curious that this did not pass to one of their three sons already working as blacksmiths. There was undoubtedly a good reason for this, but Andrew's will does not offer any clues and we can only speculate. Eldest son Joseph was already running his own separate business as a farrier (presumably the reason he is noted as being expressly excluded from his father's will). William (who you will read more about later) may not have been well enough to take over the reins, and Andrew was likely considered a little young at 17, although he probably worked for his mother.

Despite the very modern example of mother Ann as a working woman, her six daughters took on a more traditional role – domestic servants until marriage, then motherhood. The exception was Ada Sarah Leah – it would seem that her mental health may have restricted her options somewhat. She remained unmarried and living at home – in the 1901 census she is listed as feeble-minded^{xiii}, and the registration district in which she died age 35 suggests she may well have been a resident of Saint John's Hospital, the county's mental institution, at that time.

Ann herself died of heart disease in 1913 at age 69^{xiv}.



-
- ⁱ 1851 Census of Buckinghamshire, piece 1756 folio 336, Buckinghamshire Family History Society CD [transcripts of original records held at The National Archives, Kew, London]
- ⁱⁱ Marriage certificate, parish records of All Saints Church of Wing, Buckinghamshire, Church of Jesus Christ of Latter-day Saints 1042446 [Microfilm of original records held at Buckinghamshire Record Office]; also Leighton Buzzard vol 3b pg 933, Dec 1861 quarter.
- ⁱⁱⁱ Birth certificate of Ann Susan Pollard, Leighton Buzzard vol 6 pg 89, Dec 1843 quarter.
- ^{iv} Parish records of All Saints Church of Wing, Buckinghamshire, Church of Jesus Christ of Latter-day Saints 1042446 [Microfilm of original records held at Buckinghamshire Record Office]
- ^v Article from The Leighton Buzzard Observer, 14 April 1863, extract by Barbara Quick on <www.leighton-linslade.com>
- ^{vi} 1871 census, piece 1563 folio 10 pg 2, Ancestry Plus database made available through the Auckland City Library [transcripts and scans of original enumerators books held at The National Archives, Kew, London]
- ^{vii} Kelly's 1899 Directory of Buckinghamshire [need to confirm exact name], Historical Directories, <www.historicaldirectories.org>
- ^{viii} Death certificate of Andrew Pollard, Leighton Buzzard vol 3b pg 266 Mar 1898 quarter
- ^{ix} 1881, 1891 and 1901 census, Ancestry Plus database made available through the Auckland City Library [transcripts and scans of original enumerators books held at The National Archives, Kew, London]
- ^x Photo by Kevin Quick and used with permission, <www.countryviews.com>
- ^{xi} Parish records of All Saints Church of Wing, Buckinghamshire, Church of Jesus Christ of Latter-day Saints 1967010 [Microfilm of original records held at Buckinghamshire Record Office]
- ^{xii} Kelly's 1899, 1903 and 1907 Directory of Buckinghamshire, Historical Directories, <www.historicaldirectories.org>
- ^{xiii} 1901 census, piece 1509 folio 25 pg 4, Ancestry Plus database made available through the Auckland City Library [transcripts and scans of original enumerators books held at The National Archives, Kew, London]
- ^{xiv} Death certificate of Ann Susan Pollard, Leighton Buzzard vol 3b pg 389 Mar 1913 quarter

WILLIAM POLLARD AND ADA BAKER

Number nine of the thirteen Pollard children, William was born on 12 July 1877ⁱ and baptised three weeks later in the Wing parish church. Like his father Andrew and eldest brother Joseph, he was destined to become a blacksmith. He was working as a labourer for his father by age 13ⁱⁱ, and we can picture the two working side by side in the blacksmith's shop until Andrew's death in 1898.

A few months later, William married Ada Baker. Coincidentally Ada was also the ninth of thirteen children, and was born 10 October 1880ⁱ, making her a few years younger than William. Rather than marrying in the parish church, they chose to marry in the Register Office at Leighton Buzzard on 19 July 1898ⁱⁱⁱ. In attendance was George Baker, Ada's brother, and Louisa Dimmock who was a cousin to William and a second cousin to Ada and George – connected through the Hardwick clan.

There was reason for the marriage to take place so soon after William's father's death – Ada would give birth to their first child, Dorothy Gwendoline Pollard, on 27 November 1898^{iv}. Unfortunately Dorothy died before her second birthday, and was buried in Wing on 8 September 1900^{iv}.

William and Ada welcomed their second child, named after his father, on 22 August 1901. Unfortunately for little William, he would not know his father. Blacksmith William was suffering from tuberculosis, and he died on 28 March 1902, aged only 24^v. Son William was only seven months old.

Happily Ada was to find love again - on 2 August 1903 she remarried^{vi}. Percy (just Percy, not Percival) Joel Williamson was not strictly speaking a local boy, however he had been born in Cheddington, Buckinghamshire^{vii}, only four miles from Wing, so he did have a local connection. His father John George Williamson was a schoolmaster and the family of ten (not counting first child Adelaide who died as an infant) moved around from post to post, county to county, as Percy was growing up. By 1901 John Williamson had settled in Kettering, Northamptonshire⁵, and changed professions from teaching to commercial clerk. Son Percy was also a clerk, living in Willesden, Middlesex, some 32 miles from Wing, at the time of his marriage to Ada.

Ada and Percy's marriage took place in the Wing parish church and the day was a real Baker family affair. Witnesses were William Henry Baker, Ada's eldest brother, and Jenny (born Mary Jane) Baker, Ada's younger sister. William had returned home from working at the Portland Prison in Dorset for the occasion, and took the opportunity to have his daughter Nelly baptised that same day^{iv}.

⁵ The Williamson family is also linked to the shoemaking industry of Kettering – perhaps this inspired Bill Williams in his career choice?

1902 Marriage solemnized at: <u>St. Peter's Church</u> in the <u>Parish</u> of <u>Wing</u> in the County of <u>Essex</u>								
No.	When Married.	Name and Surname.	Age.	Condition.	Rank or Profession.	Residence at the time of Marriage.	Father's Name and Surname.	Rank or Profession of Father.
115	August 2 1902	Percy Williamson Ada Pollard	25 23	Bachelor widow	Clerk	Willesden Wing	John George Williamson Alfred Baker	Manager Baker
Married in the <u>Parish Church</u> according to the Rites and Ceremonies of the Established Church, by <u>Francis H. Tatham</u> or after <u>Banns</u> by me,								
This Marriage was solemnized between us,		<u>Percy Williamson</u> <u>Ada Pollard</u>	in the Presence of us,		<u>Alfred Baker</u> <u>William Baker</u>	<u>Francis H. Tatham</u>		

Figure 9: Marriage record of Ada and Percy Williamson^{iv}

After the wedding, Percy and Ada returned to Willesden to live. We next see them back in Wing baptising their daughter Evelyn Hope on 3 April 1904^{iv}. Sadly, Ada was to lose this daughter as well – Evelyn was buried in Wing on 9 March the following year.

At some point before World War One the Williamsons returned to Wing to live. Percy began working for the Rothschild family (several family members had estates in the Wing area) with their polo ponies. There were two Williamsons working there at that time – to distinguish them, Percy Williamson become Percy Williams, and the family would use Williams from this point onwards^{viii}.

During the war Percy served as a sapper with the Royal Engineers. His service in France entitled him to the British War Medal and the Victory Medal^{ix}. Upon his return the family moved to New Malden, Surrey, and he worked as a stamping clerk with the Inland Revenue^x. Ada died in 1956^{xi} and Percy followed a year later^x.

Meanwhile, son William, now known as Bill Williams, had married Winifred Grace Hall in Surrey in 1925. On to the Hall side of the family.....

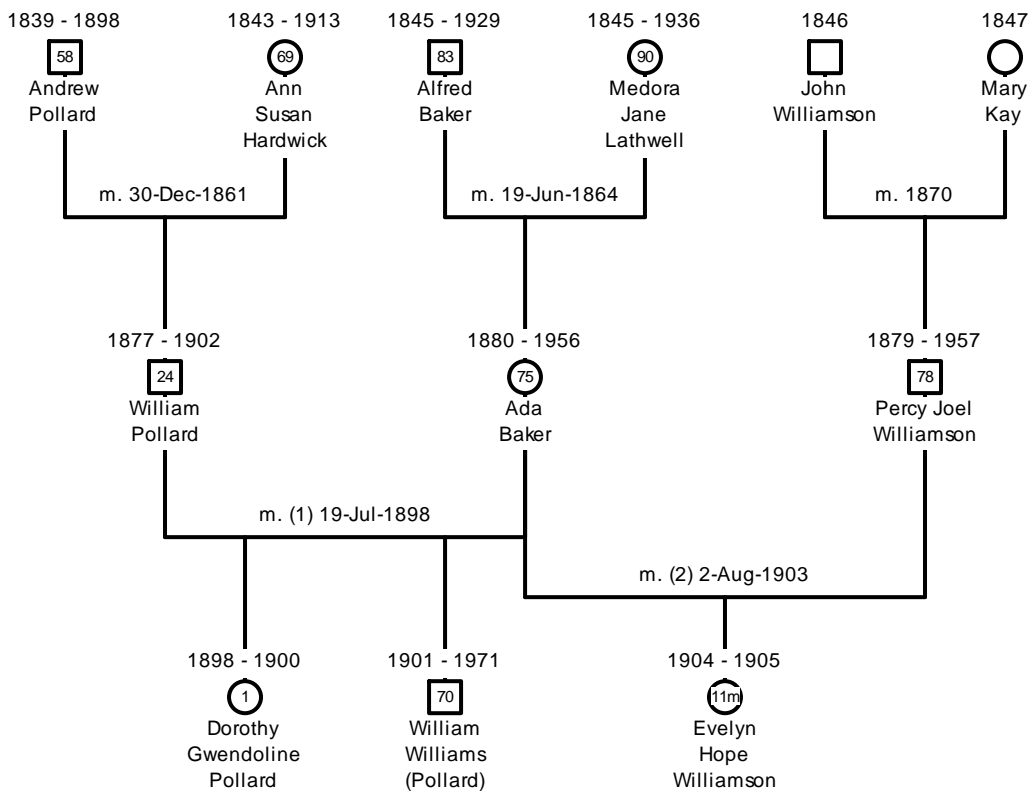

-
- ⁱ Parish records of All Saints Church of Wing, Buckinghamshire, Church of Jesus Christ of Latter-day Saints 1042447 [Microfilm of original records held at Buckinghamshire Record Office]
- ⁱⁱ 1891 census, piece 1266 folio 25 pg 10, Ancestry Plus database made available through the Auckland City Library [transcripts and scans of original enumerators books held at The National Archives, Kew, London]
- ⁱⁱⁱ Marriage certificate of William Pollard and Ada Baker. Leighton Buzzard vol 3b pg 841, Sep 1898 quarter
- ^{iv} Parish records of All Saints Church of Wing, Buckinghamshire, Church of Jesus Christ of Latter-day Saints 1967010 [Microfilm of original records held at Buckinghamshire Record Office]
- ^v Death certificate of William Pollard, Leighton Buzzard vol 3b pg 253, March 1902 quarter
- ^{vi} Marriage certificate, Leighton Buzzard vol 3b pg 888, Sep 1903 quarter
- ^{vii} 1881 census, piece 1644 folio 57 pg 23, Ancestry Plus database made available through the Auckland City Library [transcripts and scans of original enumerators books held at The National Archives, Kew, London]
- ^{viii} Email from Owen Williams, 30 September 2003
- ^{ix} World War One Medal Cards ref WO/372/21, The National Archives, online at <www.documentsonline.nationalarchives.gov.uk>
- ^x Death certificate of Percival Joel Williams, Surrey N.E vol 5g pg 507, Jun 1957 quarter
- ^{xi} Death certificate of Ada Williams, Surrey N.E vol 5g pg 477, Jun 1956 quarter